

LINDNER



**SYSTEM SOLUTIONS
PLASTICS RECYCLING**

**PURE
VALUE.**



ONLY LINDNER CLIENTS CAN TRULY SAY:

**YOU'RE AS
GOOD AS NEW.**

Hauke Grabau
Recycling Senior Associate
AST Kunststoffverarbeitung GmbH
Germany

#WASTETRANSFORMER

MAKE THE MOST OF WASTE.

SHREDDING TECHNOLOGY AND SYSTEMS ENGINEERING FOR THE RECYCLING INDUSTRY OF TOMORROW.

We believe in transforming waste into precious materials. That's why we invest all our knowledge and innovative power in shredding machines and system solutions that are highly efficient, robust, reliable and easy to maintain. So our clients can transform waste into a valuable and reusable resource – efficiently and reliably.



In-house research and development



Production on state-of-the-art machines, using the latest robotics & automation technology



In-house electrical engineering department



Consulting, engineering & system construction



Worldwide service network

Export countries



> 90

Employees worldwide



> 350

Locations worldwide



6

INNOVATION AS A PRINCIPLE – QUALITY PROMISED AND DELIVERED

Josef Lindner founded our family business in 1948. He started by planning and producing machines and systems for the wood industry. Today, more than 70 years later, the company is still family-owned, employs over 350 people worldwide and exports to more than 90 countries.

Production still takes place in Austria. In 2022, we moved into our new home of recycling, the new company headquarters in Spittal an der Drau in Carinthia, Austria. We manufacture in line with trailblazing production standards on 14,000 m² using the latest robotics & automation systems. This way, we are able to manufacture the majority of components in-house, guaranteeing our proven Lindner quality and the rapid availability of machines, systems and spare parts.



THE CYCLE STARTS HERE.

SYSTEM SOLUTIONS TO RECYCLE END-OF-LIFE MATERIALS

ZERO WASTE POTENTIAL

It is no longer possible to imagine society without polymer plastics. Despite plastic products being increasingly condemned around the world, it's virtually impossible to do without this versatile and fascinating material. For this very reason, the demand for products made from high-quality recycled materials is constantly growing, and large brands in particular want to meet this need. To do this, they need secondary raw materials in consistently high quantity and quality.

The newly founded AST centre of competence provides an impressive example of how this works, for example, with highly durable plastic containers that keep their shape. The company's long-term goal with this investment is to increase the recyclate used in its own products. The new plastics recycling line for processing post-industrial and post-consumer HDPE (high-density polyethylene) is intended – with Lindner as project partner – to create their own supply of this 'raw material'. You can read the whole success story here: <https://www.lindner.com/ast-group>



EVERYTHING FROM A SINGLE SOURCE – TURNKEY SOLUTIONS FOR MECHANICAL RECYCLING

Lindner's turnkey system solutions for plastics recycling are very much on trend. A functioning circular economy can only become a reality with high-quality recyclates. This, however, requires the right raw material. To produce it profitably with the lowest possible production costs, Lindner offers a full range of modern shredders as well as washing and sorting components from a single source. An incredibly experienced engineering team combined with perfectly tailored machines become highly productive solutions that impeccably prepare waste plastics for extrusion and get the recycling loop going.

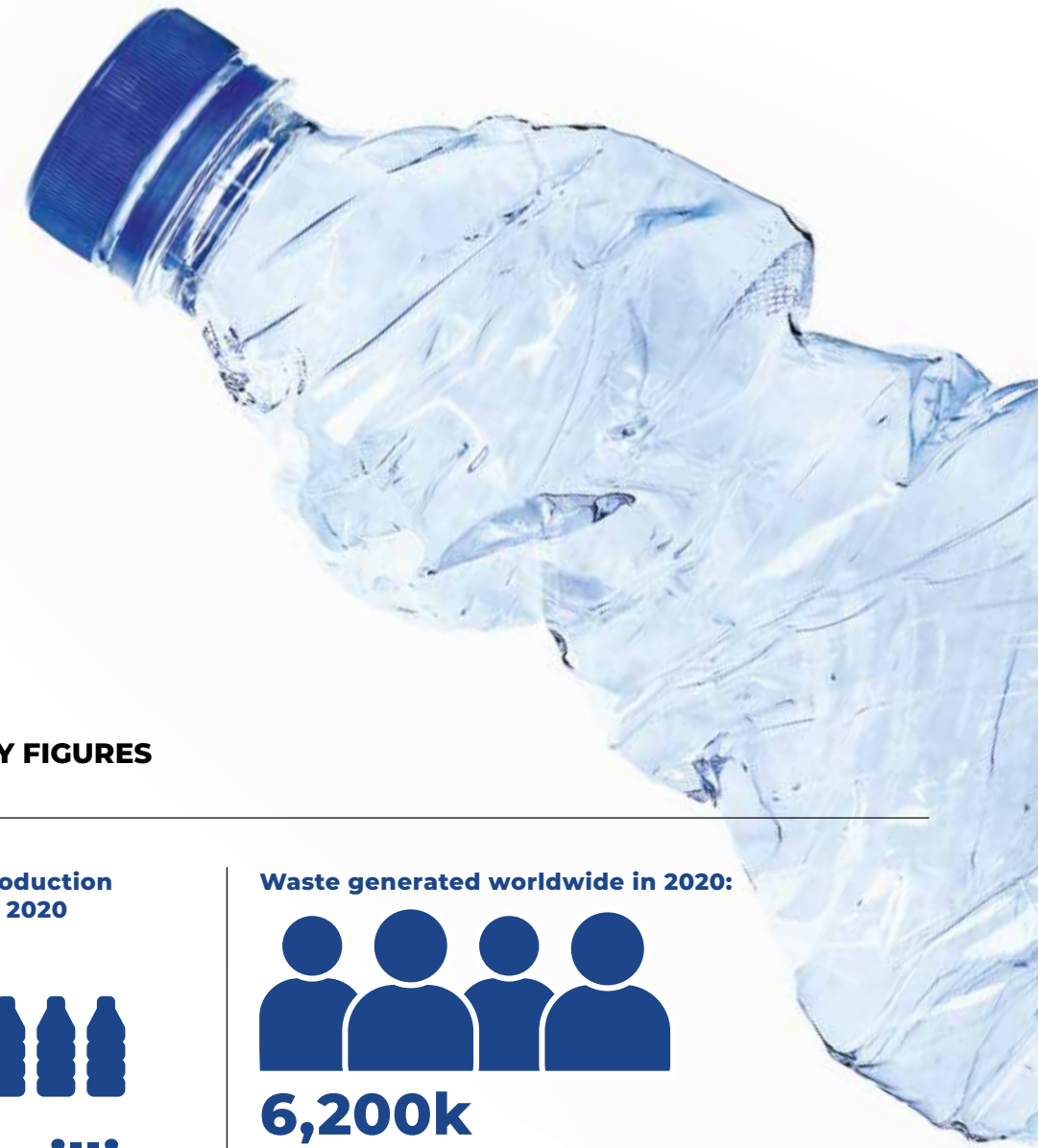

A FEW KEY FIGURES

Plastics production worldwide 2020



367 million
tonnes

Plastic waste worldwide 2019

353 million
tonnes

Of which recycled:



31,8 million
tonnes

Waste generated worldwide in 2020:



6,200k
tonnes/day

Plastic waste recycling rates (2020):

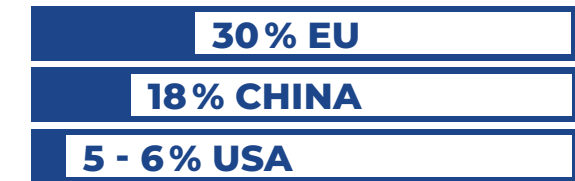

2014



311 Mt

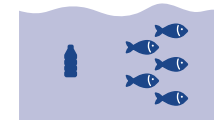

1:5

2050



1,124 Mt

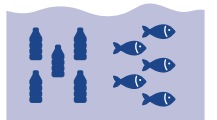

>1:1

Ratio of plastic to fish in the ocean, assuming no change in influencing factors. (by weight)

MAXIMUM VERSATILITY.

PLASTICS – A HIGHLY SOUGHT-AFTER RAW MATERIAL

FROM SUPERMARKETS TO SPACE TRAVEL

Due to plastics' countless applications, we encounter them in virtually every aspect of our daily lives. Worldwide production reached 367 million tonnes in 2020 and is rising every day. Polyethylene and polypropylene account for the largest share in terms of volume. The good news: with the right technology, discarded plastics can be transformed back into secondary raw materials, saving precious resources at a profit.

19,7% PP

Containers, food packaging, tubes, closures, toys, car parts, garden furniture etc.

17,4% PE-LD, PE-LLD

Consumer, industrial and agricultural films, Food packaging etc.

12,9% PE-HD, PE-MD

Toys, milk bottles, Household goods, pipes, cosmetic bottles etc.

8,4% PET

Beverage bottles, trays, foils, textile fibres etc.

10,7% OTHER THERMOPLASTICS

9,6% PVC

Window profiles, floor coverings, cables, toys, hoses etc.

7,8% PUR

Insulation material, pillows, mattresses etc.

7,4% OTHER PLASTICS

Insulation material, pillows, mattresses etc.

6,1% PS, PS-E

Spectacle frames, cups, packing, insulation material etc.

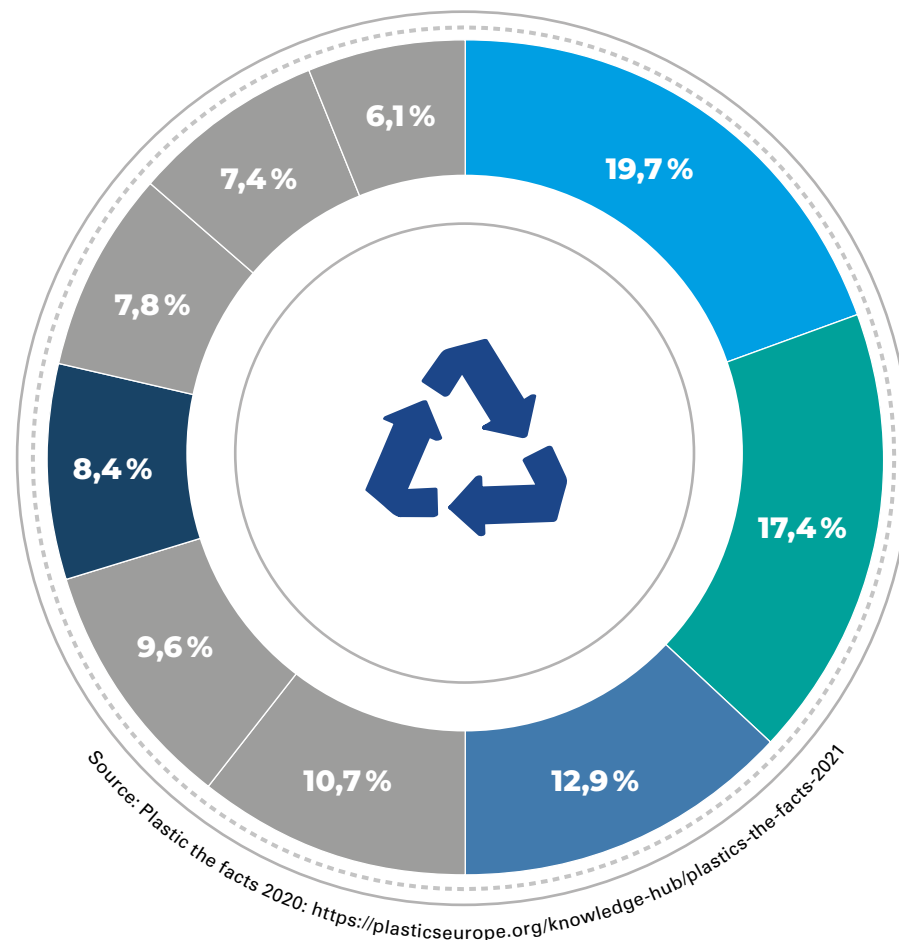

Source: Plastic the facts 2020: <https://plasticseurope.org/knowledge-hub/plastics-the-facts-2021>

PE-LD & PE-LLD FILM



Large quantities of film are part of the waste stream as post-consumer, post-commercial or agricultural film. They are usually contaminated with organic waste and paper labels. Thanks to modern multi-stage processing and state-of-the-art washing technology, it's possible to produce perfectly customised flakes that are ideal for extrusion.

PE-HD BOTTLES



PE-HD bottles are traded in pre-sorted and pressed form. The purity of these materials varies greatly depending on their origin. Lindner's hot-wash system can be used to produce such a high-quality regrind that it can even replace virgin PE-HD – the basis of a genuine circular economy.

PP CONSUMER GOODS



PP waste is generated as mono or mixed fractions while sorting commercial or bulky waste. The robust shredder, which is resistant to non-shreddables, reliably shreds these materials into sortable flakes. These are then cleaned and, particularly importantly, separated to obtain a homogeneous source material for new, high-end products.

PET BOTTLES



Next to polyolefins, PET is one of the most commonly used plastics for packaging. In order for PET to be successfully recycled and reused in the food industry, the focus is not only on professional shredding but also on the demanding cleaning process.

SUCCESS ALL ALONG THE LINE.

POST-CONSUMER PLASTICS RECYCLING

Lindner's multi-stage processing facility for post-consumer plastic is in a class of its own. Perfectly matched components ensure superb output quality. Robust high-end shredding, washing and drying technology is the key to smooth 24/7 operation with low maintenance requirements and consistently high throughput. It has never been easier to guarantee the ideal input for subsequent processes.

1. SHREDDING

2. PRE-WASHING

3. FRICTION WASHING

4. SEPARATION

5. MECHANICAL DRYING

6. THERMAL DRYING

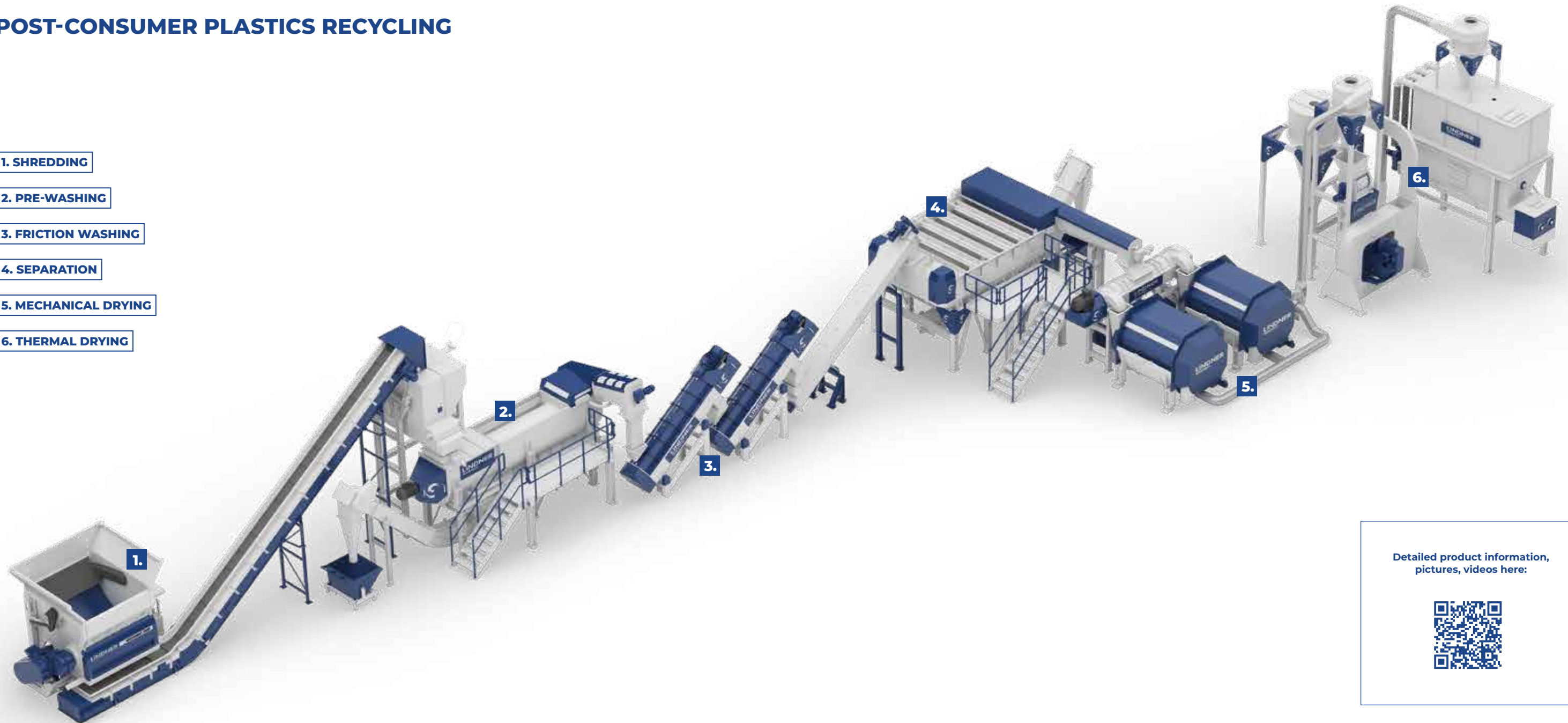

Detailed product information,
pictures, videos here:



NOTHING TO WASTE.

POST-INDUSTRIAL PLASTICS RECYCLING

With our compact solution combining a primary shredder and granulator, it has never been easier to prepare plastic waste, defective products or offcuts for re-entering the production cycle. Enjoy maximum productivity with our highly efficient, robust and low-maintenance components.

1. PRIMARY SHREDDING

2. CONTAMINANTS DETECTION

3. GRANULATION

4. GRANULATE COLLECTION



Detailed product information,
pictures, videos here:



IT'S GOT SYSTEM.



Individual systems - turnkey from one single source.

For many decades, we have been designing, planning and building plastics recycling plants tailored to individual customer requirements for a wide range of applications - worldwide - together with Lindner Washtech, our subsidiary specialist in plastics recycling. Together we offer solutions for robust and powerful primary shredding, sorting, flexible and precise secondary shredding as well as multi-stage and high-performance washing technology with water treatment. The perfect coordination of the four key components - shredding, sorting, washing and drying - is the key to high and consistent quality of the granulate and the cornerstone for successful plastics recycling.

High reliability with superior depth of added value, decades of experience and the many Lindner in-house services:

- Experienced systems engineering team
- In-house electrical and electronic production as well as in-house software development
- Commissioning and training by qualified experts
- Individual fine-tuning on site
- Fast spare parts supply worldwide in 100% Lindner original parts quality
- 24/7 service & maintenance worldwide

THERE'S MORE TO IT.



ELECTROMECHANICAL BELT DRIVE

Using an electromechanical belt drive, Lindner has opted for technology that has been tried and tested for decades and does not require any special parts. This means that spare parts are readily available should the need arise. Compared to other systems available on the market, maintenance and repairs can be carried out much more cost-effectively and also very quickly.



EASY MACHINE ACCESS

All of Lindner's shredders have two things in common: easy access to the rotor as well as quick and safe access to the screen unit. Thanks to the hydraulically operated, inward-swivelling door for maintenance and non-shreddables removal non-shreddables can be extracted quickly and safely even if the machine is full. Furthermore, the easy access to the rotor makes sure that changing the knives is easy and convenient. The result: maximum availability.

MECHANICAL SAFETY CLUTCH

The torque-limiting safety clutch ensures optimal protection of the drive unit thanks to instant mechanical disengagement. The highly precise sensors ensure a controlled machine shutdown and therefore protection for all components.

Flexibly adjustable, the safety clutch can be adapted precisely to the material, preventing false triggering. The machine is restarted normally after the non-shreddables have been removed, without any need for mechanical resetting.



SUPERIOR WELDING QUALITY

Superbly trained employees and investments in state-of-the-art production and automation systems are the key to unparalleled precision and welding quality.



PERFECTLY TUNED.



In-house power electronics included.

Lindner's systems and individual machines perform even under the most extreme conditions – 7 days a week, 365 days a year. The secret – apart from decades of experience – lies in the interplay of three essential areas: shredding technology, power electronics and software. This way, all control parameters as well as the mechanical system, the hydraulics and the electronics are always optimally matched and guarantee the best quality and the longest service life.

All advantages at a glance:

- In-house planning and manufacturing
- Special designs for operation in particularly dusty environments
- Variable speed control thanks to the frequency converter that ensures the optimum operating point
- Low operating costs due to avoidance of power peaks and smooth starts
- High efficiency for low energy consumption



THE RIGHT SOLUTION.

ATLAS 5500 AS

Primary shredding



JUPITER SERIES

Primary shredding



KOMET SERIES

Granulation



MICROMAT SERIES

Universal Shredding



ANTARES SERIES

Universal Shredding



Cutting system:	Asynchronous two-shaft system with solid welded rippers and scraper unit	Single-shaft system with screwed pointed knives, two rows of stator knives and defined particle sizes thanks to sickle-shaped or hexagonal screens	Single-shaft system with screwed knife rows, two rows of stator knives and defined particle sizes thanks to round hole or hexagonal screens
Drive:	Electromechanical belt drive with planetary gears and dynamic energy exchange (DEX)	Electromechanical countershaft drive and additional flywheel energy storage for particularly tough materials	Electromechanical belt drive. Optional: high-performance (HP) version with an even more powerful drive and additional rows of knives
Speed range:	22 – 36 rpm	31 – 87 rpm	158 – 367 rpm
Particle sizes:	150 – 400 mm	100 – 300 mm	10 – 90 mm

Cutting system:	Single-shaft shredders with different rotor systems, including the universal Mono-Fix system. Defined particle sizes through round hole or hexagonal screens	Single-shaft shredders with different rotor systems, including the universal Mono-Fix system. Defined particle sizes through round hole or hexagonal screens
Drive:	Optional powerful gear drive with powerful and proven motors or direct belt drive (HP) for maximum throughputs	Robust gear drive with proven asynchronous motors and high torque
Speed range:	80 – 265 rpm	80 – 100 rpm
Particle sizes:	10 – 250 mm	10 – 80 mm



ATLAS 5500 AS

MERCILESSLY EFFICIENT.



Productivity from start to finish.

Based on the proven belt concept, the Lindner's Atlas 5500 AS twin-shaft primary shredder sets new efficiency standards with its high-performance planetary gears, innovative DEX (Dynamic Energy Exchange) energy recovery system and asynchronous shaft control. Delivering consistently high throughput, built for tough applications and equipped with the innovative FX fast exchange system, this shredder provides maximum uptimes and can be relied on to keep the line going.

- Asynchronous ripper rotor principle for continuous material output in both directions of rotation
- Highest energy efficiency thanks to DEX – Dynamic Energy Exchange
- Ideal particles for downstream sorting processes
- Maximum resistance to non-shreddables
- High operational availability due to extra-long uptimes and the quick exchange of the complete cutting unit (FX)
- Optional: drive unit with convenience & maintenance functions

ASYNCHRONOUS TWIN-SHAFT CUTTING SYSTEM WITH DYNAMIC ENERGY EXCHANGE SYSTEM (DEX)

- 1. Highly efficient electromechanical belt drive with planetary gears
- 2. DEX – Smart energy management system
- 3. Mechanical safety clutch
- 4. Twin-shaft cutting system
- 5. FX – Fast exchange system
- 6. Controlling & operation
- 7. Chassis

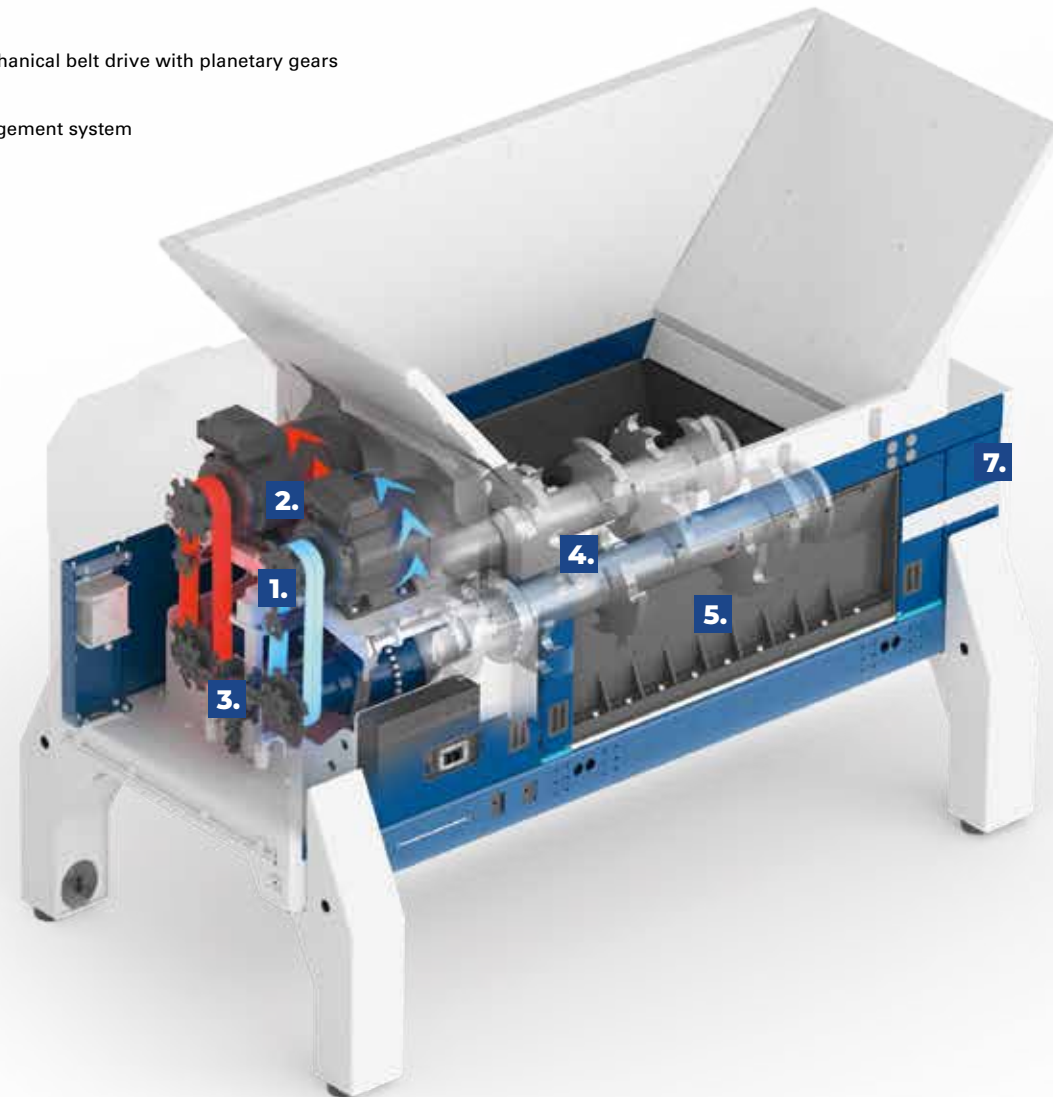

ASYNCHRONOUS TWIN-SHAFT CUTTING SYSTEM

The cutting system of the Atlas AS consists of two asynchronously running, fully welded rotors and a solid scraper unit. The asynchronous ripping (ripping apart, ripping up) at low speeds and high torque combined with the dynamic energy recovery enables:

- Aggressive material intake
- Continuous volume flow
- Highest productivity
- Ideal output material for sorting

DRIVE UNIT WITH CONVENIENCE & MAINTENANCE FUNCTIONS (OPTIONAL)

Lindner's ATB – automatic belt tensioning system:

- Ensures optimum power transmission at all times
- Belt exchange using a hydraulic tensioning device
- Self and preventive monitoring

Compressed air ventilation drive unit:

- Protects the drive unit from dirt
- Significantly reduced maintenance activities
- With radial fan and self-cleaning function

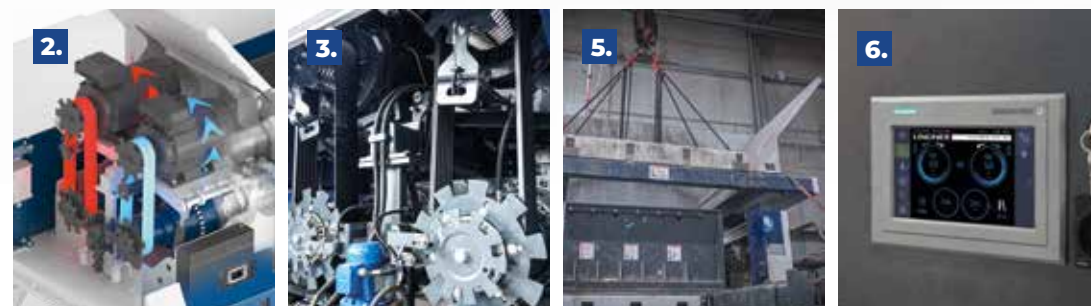

Detailed product information, pictures, videos here:



LINDNER'S DEX – DYNAMIC ENERGY EXCHANGE SYSTEM – FOR MAXIMUM EFFICIENCY

Maximum efficiency is achieved by actively using braking energy when reversing one of the shafts. Top productivity is ensured with an instant, power electronics-controlled reversal of the shaft running direction. It can be used anywhere thanks to the ingeniously simple combination of tried-and-tested components.

- Innovative, load-dependent energy management
- Highest energy efficiency in operation
- Maximum agility while changing the running direction, up to 3 times faster

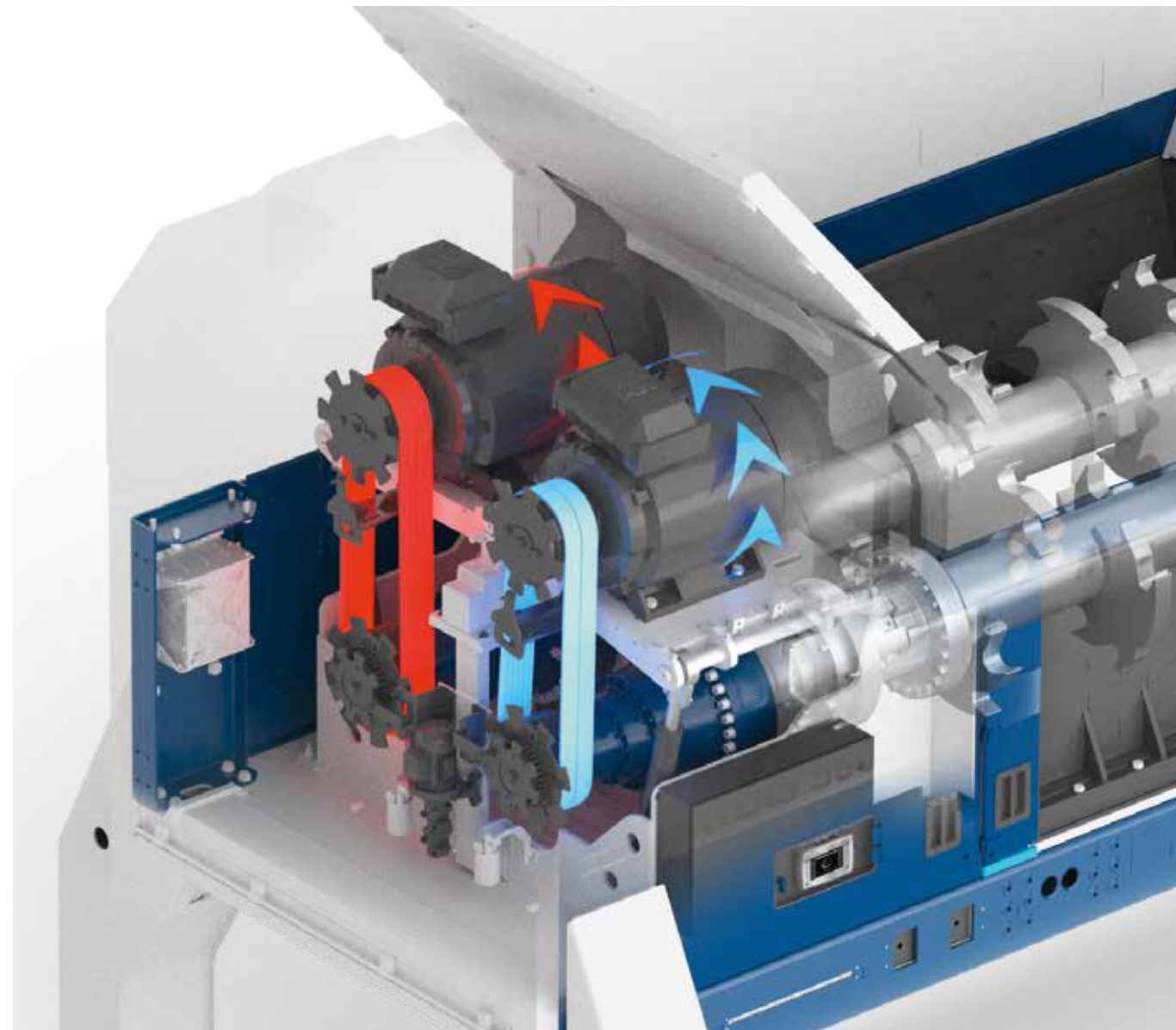

OUR UNIQUE FAST EXCHANGE SYSTEM (FX)

The Atlas series has been perfected to give you easy access to the cutting unit and provides two options for removing or changing the entire cutting unit or individual components. The components can be removed from the side via the hydraulically operated, swivelling slider or, after removal of the hopper, from the top.



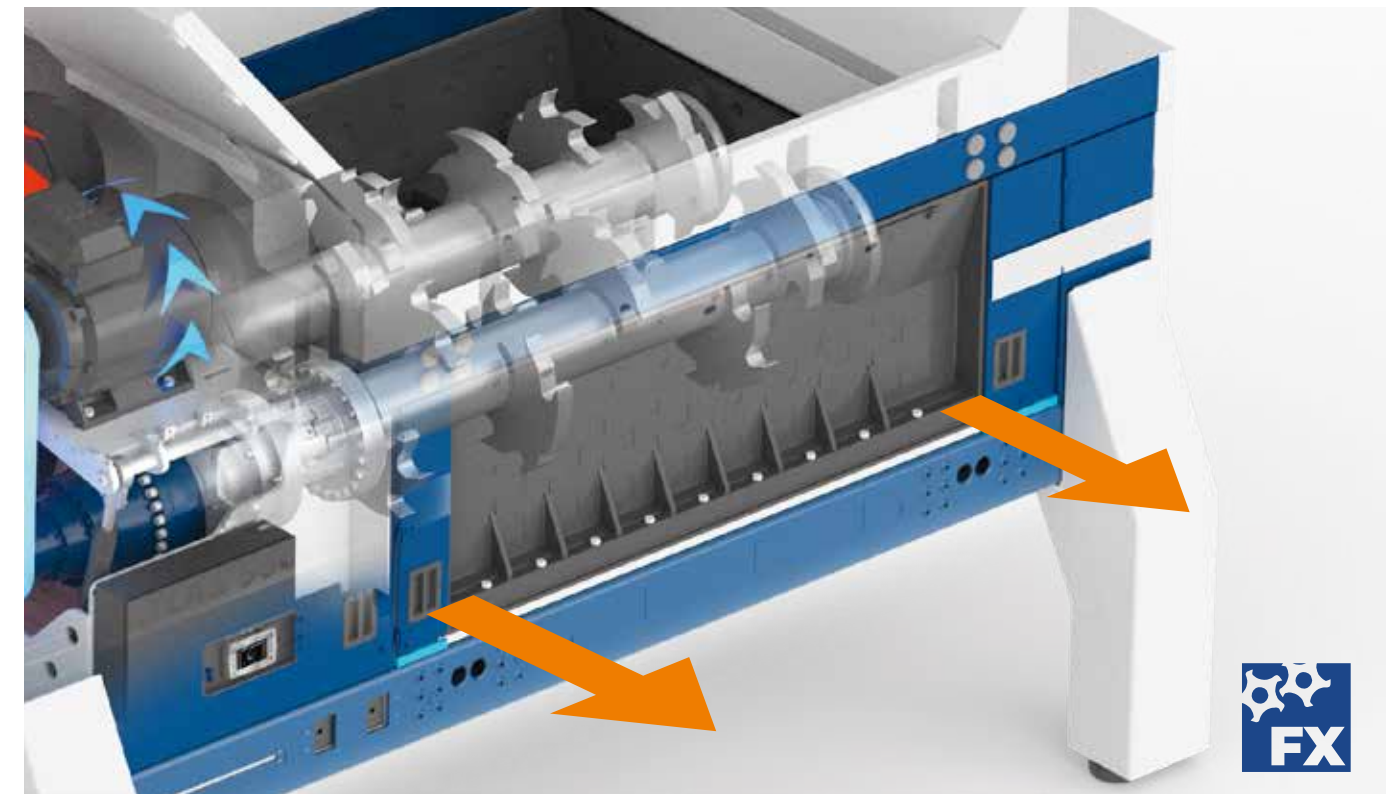
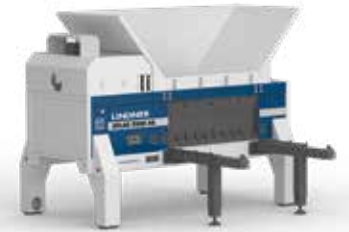

- The cutting unit can be exchanged quickly, ensuring minimum downtime
- The two quick-change options guarantee maximum flexibility
- Easy and fast removal of the hopper



THE ATLAS SERIES SOLID TWIN-SHAFT CUTTING SYSTEM

- Solid twin-shaft cutting system
- Aggressive material intake for highest throughputs – optimised for defined output material in the primary shredding stage
- Customised shaft tools for different applications
- Solidly built scraper unit



-  Water sprinkling system
-  Automated belt tensioning
-  Hardfacing kit (Shafts & frame)
-  Fire prevention system
-  Fast exchange system

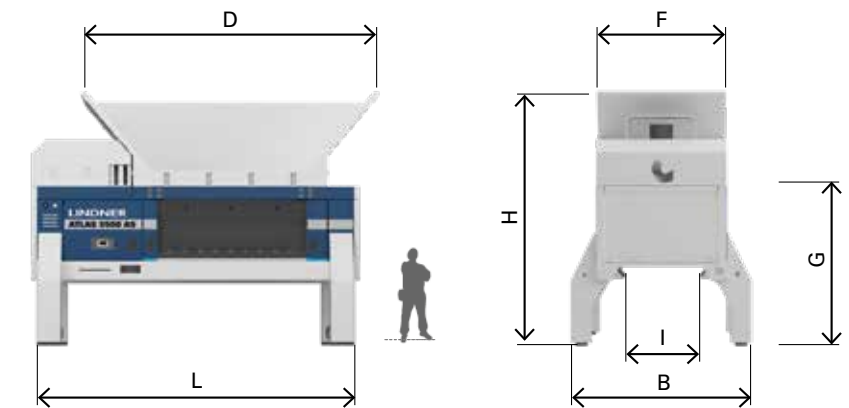

Typical input/output materials



ATLAS		5500 AS
DIMENSIONS*		
Measure (LxWxH)	mm	6150 x 3390 x 4810
Hopper opening (DxF)	mm	5470 x 2230
Feeding height (G)	mm	3310
Hopper capacity	m ³	18
Outlet width (I)	mm	1510
Total weight	kg	35000
CUTTING UNIT*		
Length	mm	2 x 2380
Speed	min ⁻¹	36
Standard tool		AS 4.8 AS 4.12.
DRIVE UNIT*		
Motor	kW	2 x 110
Frequency converter		✓

* The stated values refer to standard machine versions with a standard hopper (large) and raised feet.

JUPITER 1800 | 2200 | 3200 | 2200 HP

PRIMARY SHREDDING AT ITS BEST.



Gets the process going: Reliably high output and consistent particle sizes.

The Lindner Jupiter single-shaft primary shredder combines everything you need for efficient 24/7 operation: a powerful countershaft drive, a well-engineered machine design and high manufacturing quality. Undefeated by non-shreddables, our tried-and-tested technology ensures a long service life and low maintenance coupled with the necessary power to shred even the toughest materials – year after year and ton after ton.

- Particularly resistant to non-shreddables
- Additional flywheel mass for very tough materials
- Consistently high throughputs thanks to precise cutting action
- Four-fold usable rotor knives

SINGLE-SHAFT PRIMARY SHREDDER WITH POWERFUL COUNTERSHAFT DRIVE FOR 24/7 OPERATION

- 1. Pusher
- 2. Countershaft drive
- 3. Plug & go screen unit
- 4. Chassis
- 5. Safety clutch
- 6. Maintenance door
- 7. Cutting unit

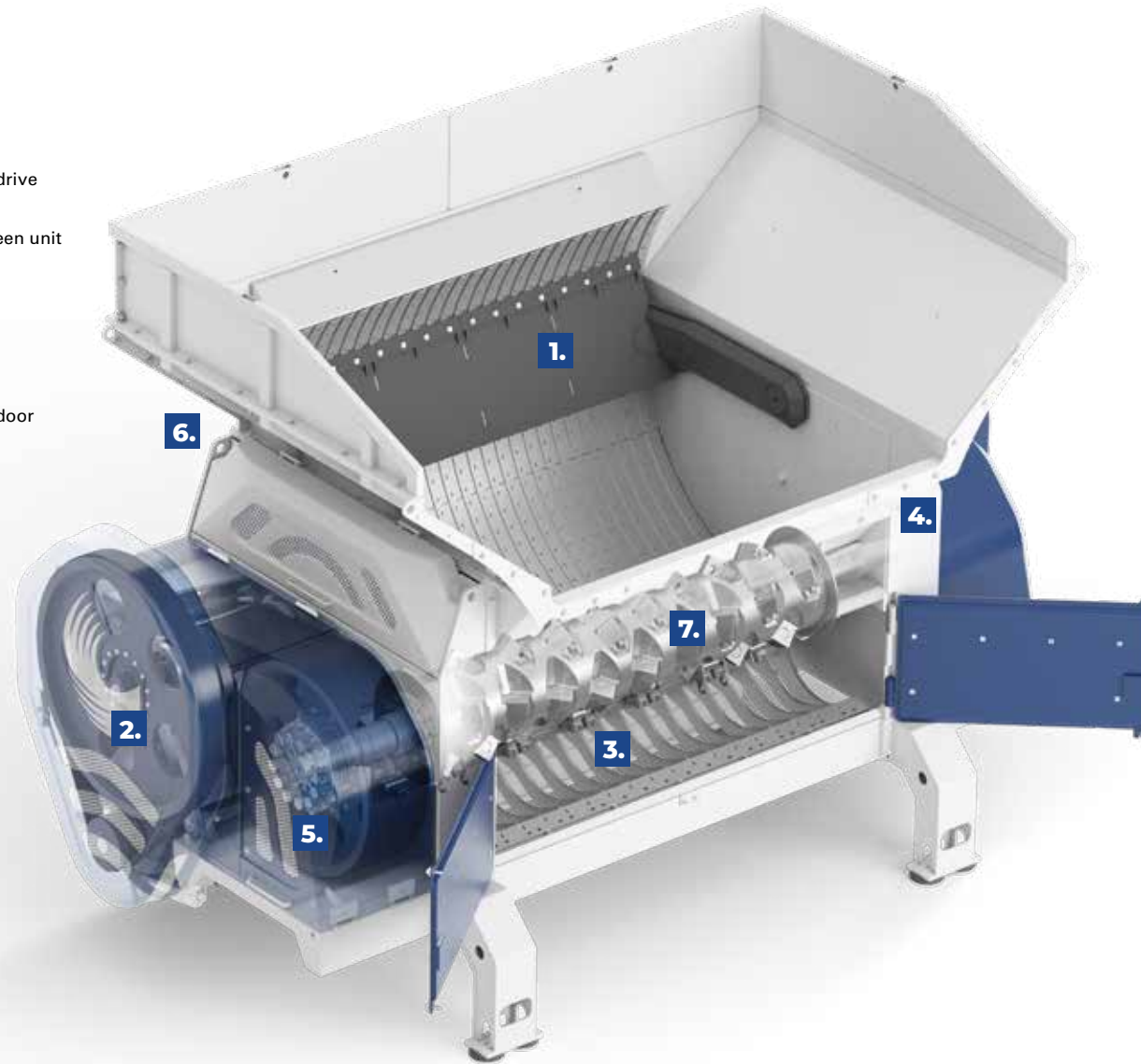

SINGLE-SHAFT CUTTING SYSTEM WITH FOUR-FOLD USEABLE POINTED KNIVES

- Solidly built knives and knife holders particularly resistant to non-shreddables
- Maximum availability, as knives can be changed quickly
- Easily adjustable cutting gap for optimum output quality

COUNTERSHAFT DRIVE WITH FLYWHEEL ENERGY STORAGE

Less energy consumption and more power thanks to the countershaft drive that stores and releases rotational energy depending on the load.

- Highest energy efficiency
- Consistently high throughput even with tough materials
- Spare parts obtainable worldwide
- Also available as a HP model (high performance model) for even more power and throughput

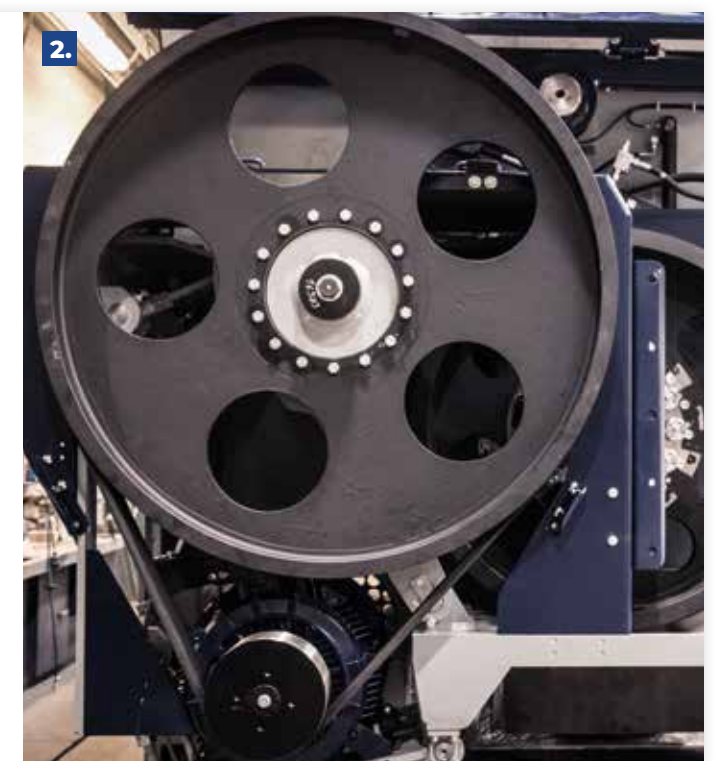

Detailed product information, pictures, videos here:



THE JUPITER SERIES CUTTING SYSTEM

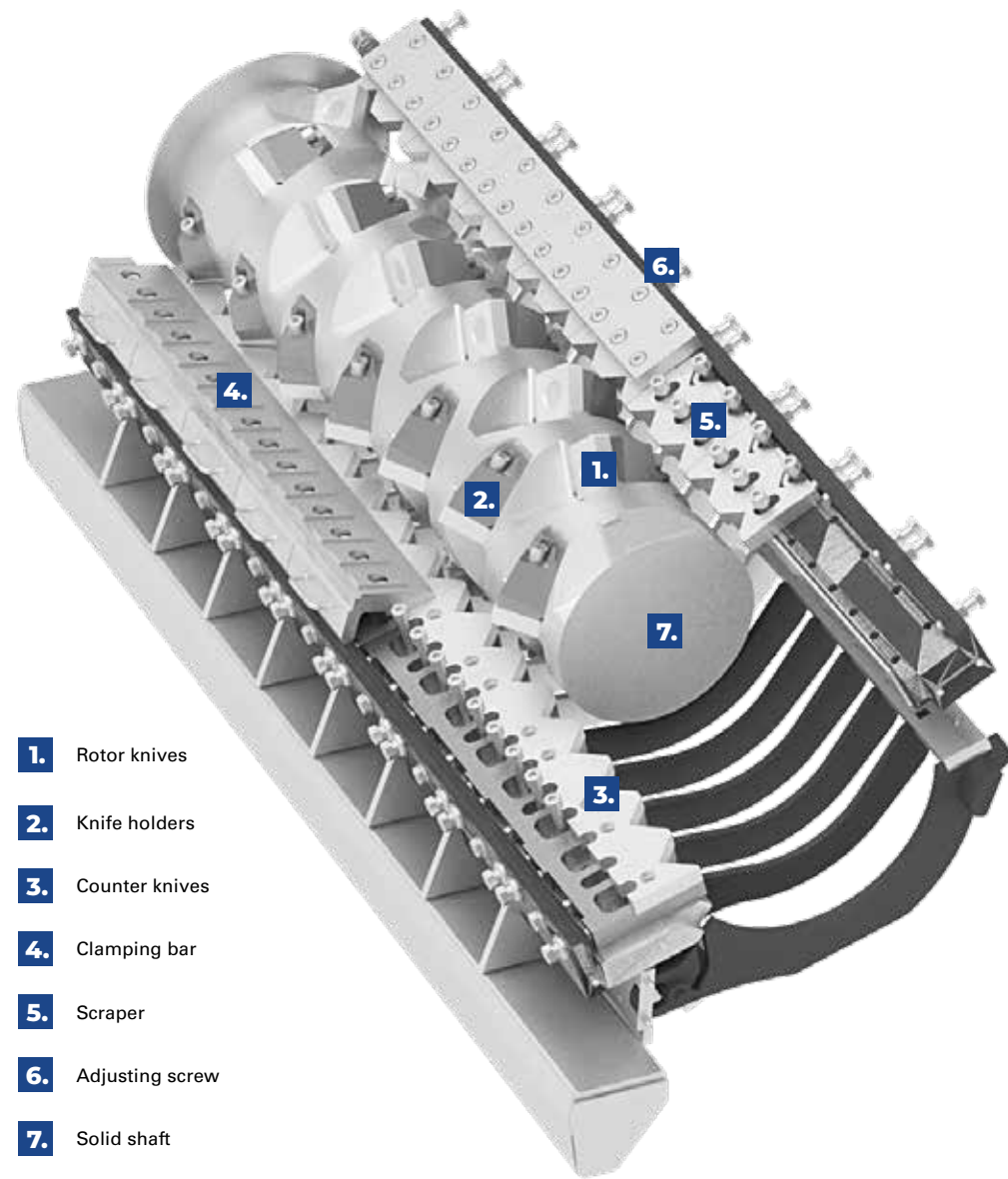

Rotor with pointed knives in 3 knife sizes, four-fold usable



- 1. Rotor knives
- 2. Knife holders
- 3. Counter knives
- 4. Clamping bar
- 5. Scraper
- 6. Adjusting screw
- 7. Solid shaft

- Water sprinkling system
- Fire prevention system
- Bale opener
- High performance

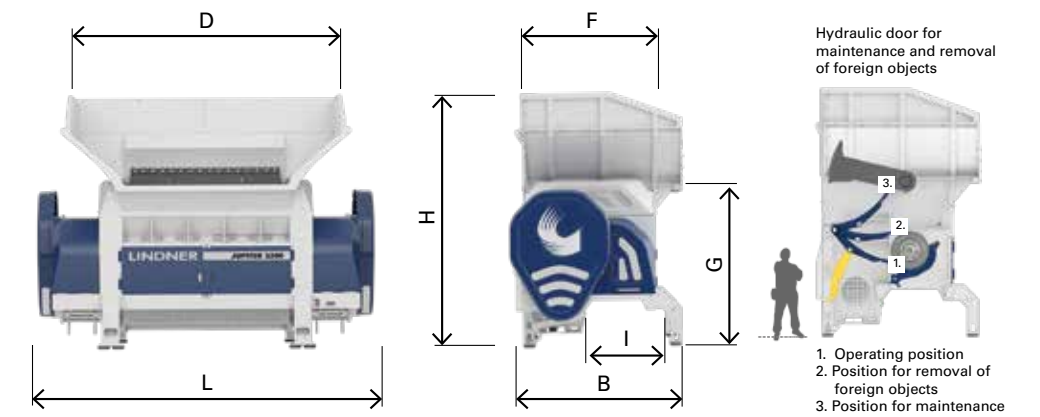

Typical input/output materials



JUPITER	1800	2200	3200	2200 HP
DIMENSIONS*				
Measure (LxBxH)	mm 4800 x 3270 x 4840	5500 x 3270 x 4840	6500 x 3270 x 4840	5500 x 3270 x 4840
Hopper opening (DxF)	mm 3750 x 3000	4090 x 3000	5150 x 3000	4090 x 3000
Filling height (G)	mm 3105	3105	3105	3105
Hopper volume	m ³ 7,5	9	12	9
Outlet width (I)	mm 1020	1020	1020	1020
Total weight	kg 25800	32750	39000	33750
CUTTING UNIT*				
Rotor length	mm 1770	2115	3170	2115
Rotor speed	min ⁻¹ 58/87	51/87	58/87	58/87
Pointed knives	mm 145P 116P 87P	145P 116P 87P	145P 116P 87P	145P 116P 87P
Number of knives	pcs. 20 22 41	24 28 50	36 42 77	24 28 50
Screens: hexagonal/sickle-shaped	✓	✓	✓	✓
Number of screens	pcs. 4/1	4/1	6/1	4/1
DRIVE UNIT*				
Motor	kW 1 x 200	2 x 132	2 x 160	2 x 200
Frequency converter	✓	✓	✓	✓

* The stated values refer to standard machine versions with a standard hopper and raised feet. The right to make technical changes is reserved.

KOMET 1800 | 2200 | 2800 | 2200 HP | 2800 HP

IMPOSSIBLY RELIABLE & INCREDIBLY PRECISE.



Precision that's a cut above the rest.

The Lindner Komet sets new standards in single-shaft shredding. Whether you are processing municipal or bulky refuse, industrial or commercial waste, textiles, waste paper or other materials – the Komet ensures smooth processes 24/7 thanks to its robust design, high-precision tools and smart features. Benefit from its first-rate particle quality and superb efficiency.

- The benchmark in secondary shredding
- 24/7 reliability
- Highest precision cutting for outstanding output quality
- HP (high performance) version for even more throughput
- Optional: Drive unit with convenience & maintenance functions

HIGHLY PRECISE SINGLE-SHAFT SECONDARY SHREDDER FOR POWERFUL NON-STOP OPERATION

- 1. Internal pusher
- 2. Single-step belt drive
- 3. Plug & go screen unit
- 4. Chassis
- 5. Safety clutch
- 6. Maintenance door
- 7. Cutting unit

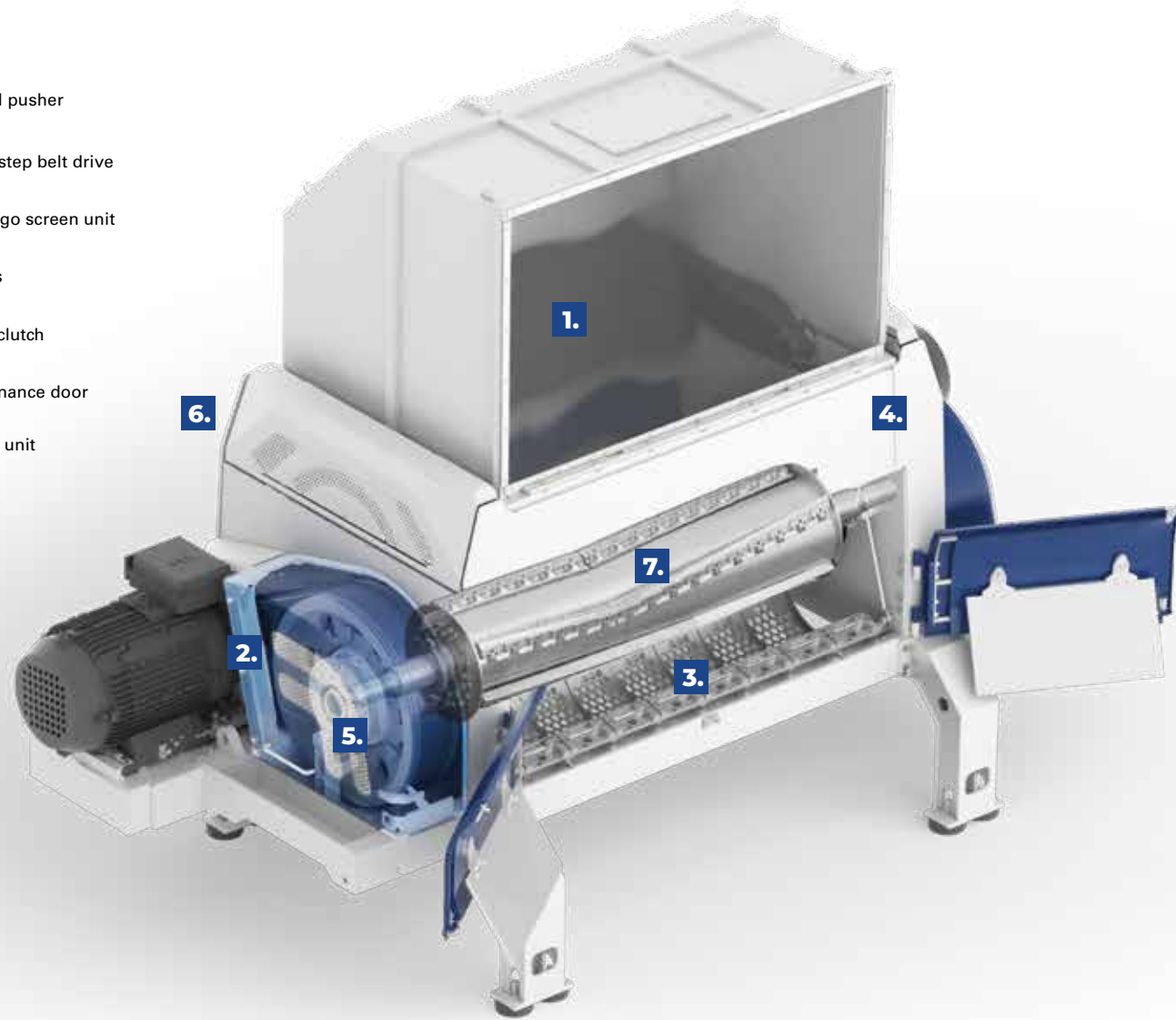

PRECISE ROTOR WITH SQUARE KNIVES

- High throughputs guaranteed thanks to the strategically positioned knife rows
- Consistent particle size with a cutting gap that is fully adjustable even during operation
- Optimised wear parts storage thanks to identical knives for the rotor, counter knives and scraper
- Maximum uptimes ensured by four-fold usable, quick-change knives

TRIED-AND-TESTED BELT DRIVE

- Efficient, robust and gearless belt drive
- Worldwide availability of easy-to-change standard components
- Mechanical safety clutch for maximum resistance to non-shreddables
- HP (high performance) option for even higher productivity
- Optional: Comfort function for automatic belt tensioning

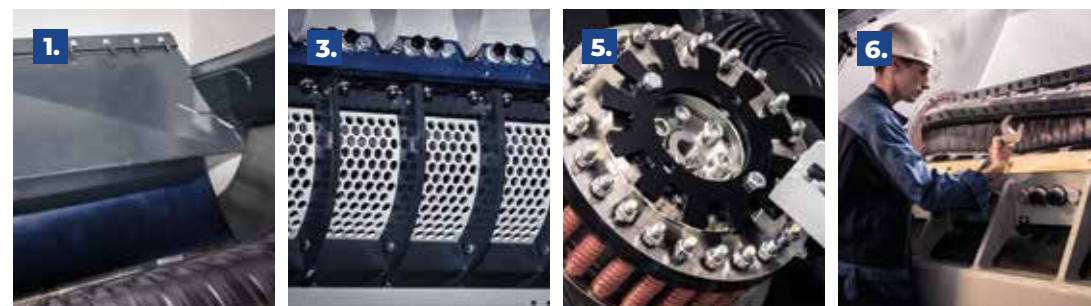

Detailed product information, pictures, videos here:



THE KOMET SERIES CUTTING SYSTEM

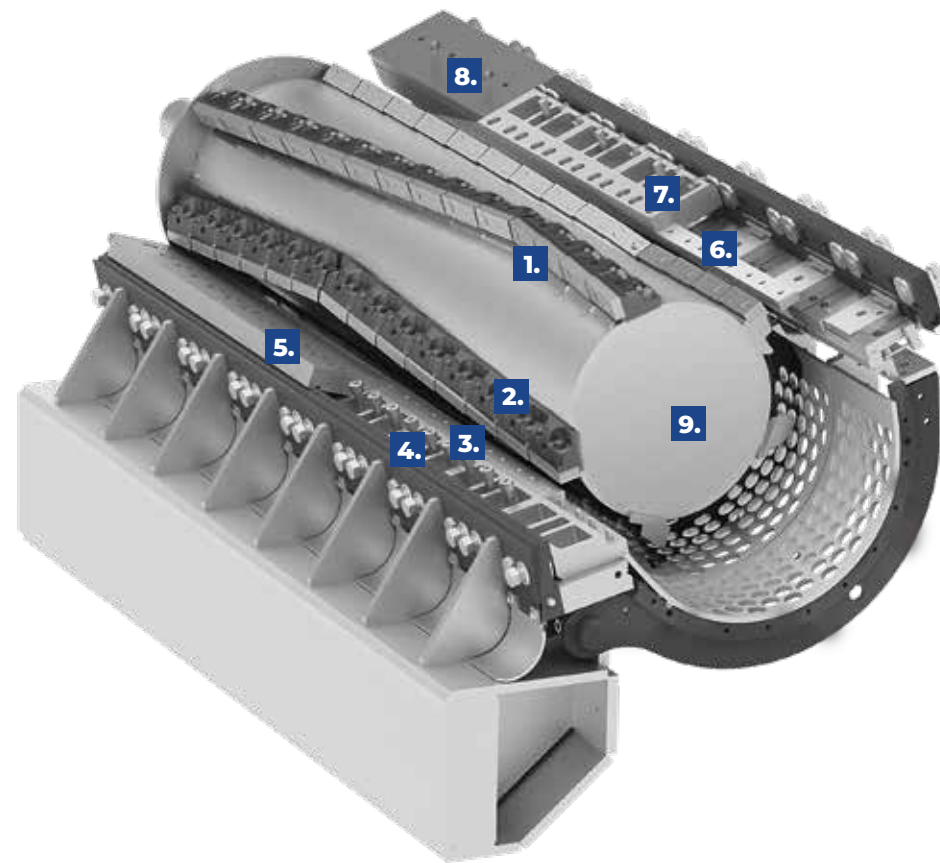

Rotor with square knives – four-fold usable

- 1. Rotor knives
- 2. Knife holders
- 3. Counter knives
- 4. Counter knife slider
- 5. Clamping bar
- 6. Scraper
- 7. Scraper slider
- 8. Clamping bar
- 9. Solid shaft

- ATB** Automated belt tensioning
- FPS** Fire prevention system
- Rotor cooling
- HP** High performance

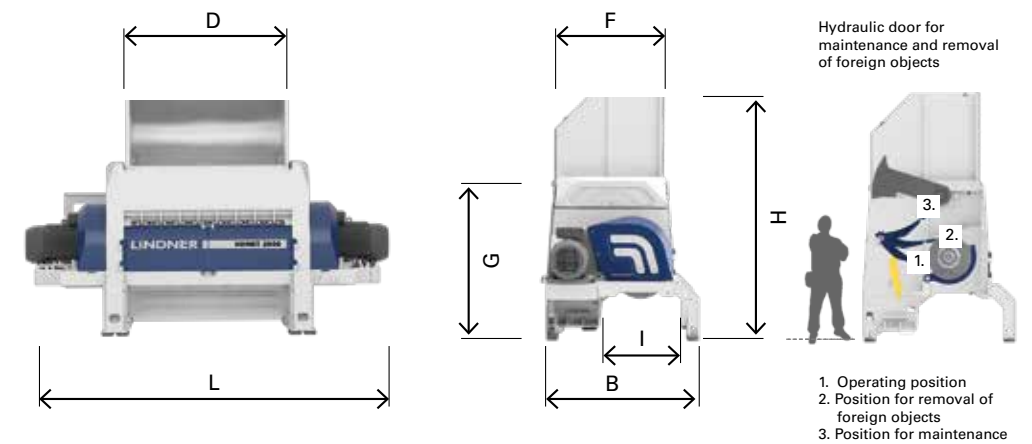

KOMET		1800	2200	2800	2200 HP	2800 HP
DIMENSIONS*						
Measure (LxBxH)	mm	4915 x 2925 x 4840	5755 x 2925 x 4840	6445 x 2925 x 4840	5815 x 2925 x 4840	6700 x 2925 x 4840
Hopper opening (DxF)	mm	1790 x 2030	2135 x 2030	2825 x 2030	2135 x 2030	2825 x 2030
Filling height (G)	mm	3111	3111	3111	3111	3111
Hopper volume	m ³	3,3	4	5,3	4	5,3
Outlet width (I)	mm	960	960	960	960	960
Total weight	kg	19600	23300	27500	24000	29900
CUTTING UNIT*						
Rotor length	mm	1770	2115	2805	2115	2805
Rotor speed	min ⁻¹	355	355	355	355	367
Standard: Blade knives		172R	172R	172R	172R	172R
Number of knives	pcs.	50	60	80	84	112
Screens: hexagonal / round		✓	✓	✓	✓	✓
Number of screens	pcs.	5	6	8	6	8
DRIVE UNIT*						
1-step belt drive		✓	✓	✓	✓	✓
Motor	kW	1 x 200	2 x 132	2 x 160	2 x 200	2 x 250
Frequency converter		✓	✓	✓	✓	✓

* The stated values refer to standard machine versions with a standard hopper and raised feet. The right to make technical changes is reserved.

Typical input/output materials



MICROMAT 1500 | 2000 | 2500 | 1500 HP | 2000 HP | 2500 HP

GETS ME MORE.



This is what gives foils the rest: Totally special, for maximum quality.

The single-shaft shredder in combination with its powerful gear or direct belt drive and its unique Mono-Fix technology make the Micromat series the benchmark for shredding post-consumer or industrial waste. The Lindner Mono-Fix system allows knives and knife holders to be changed with just a single screw. Different pointed and flat knives as well as blind plates and special counter-knives can be used on the same rotor body - so the cutting system can be easily and effortlessly adapted to different input materials, which in turn has a positive effect on quality and throughput.

- Robust construction, easy maintenance, operation and feeding
- Mono-Fix technology enables maximum adaptation to the input material and granulate size
- Flexible adjustment of the cutting unit enables consistently high throughput even for tough materials
- Also available in an HP (high performance) version for even greater throughput

SINGLE-SHAFT UNIVERSAL SHREDDER WITH POWERFUL DRIVE AND MONO-FIX TECHNOLOGY

- 1. Powerful gear drive or direct belt drive
- 2. Handling & operation
- 3. Maintenance door
- 4. Cutting unit
- 5. Internal pusher
- 6. Plug & go screen unit

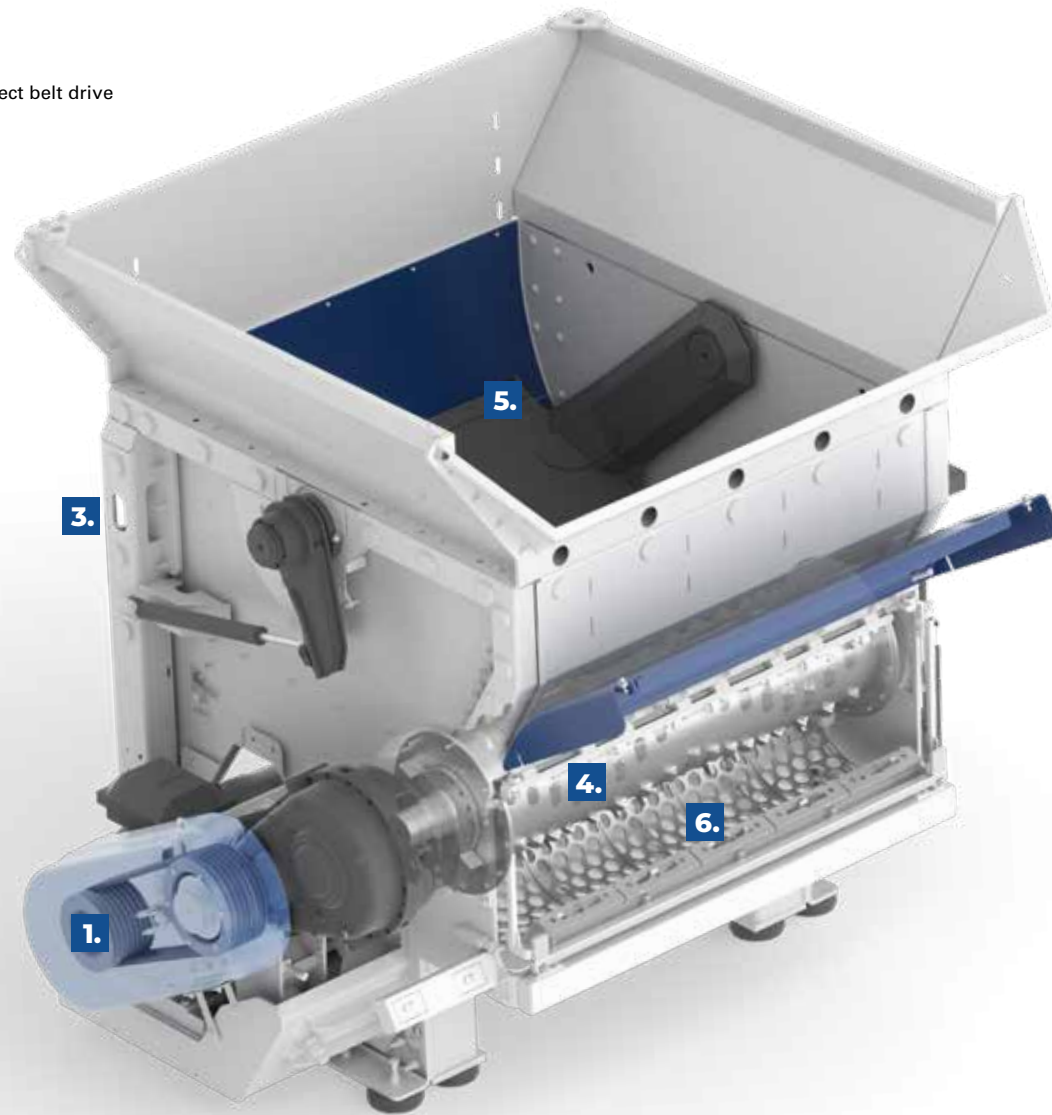

Detailed product information, pictures, videos here:



MONO-FIX TECHNOLOGY

The Mono-Fix system allows knives and knife holders to be changed with just one screw. Different pointed and flat knives, as well as blind plates and special counter knives, can also be attached to the rotor in a combined way. The result:

- Maximum flexibility of the cutting unit
- Maximum adaptation to input and particle size

POWERFUL DRIVE SYSTEMS

Optionally powerful gear drive with high-performance and proven motors for optimum shredding of, for example, dimensionally stable plastics, fibers, nets or big bags - or as direct belt drive (HP) for maximum throughputs when shredding, for example, post consumer films.



THE MICROMAT SERIES CUTTING SYSTEM

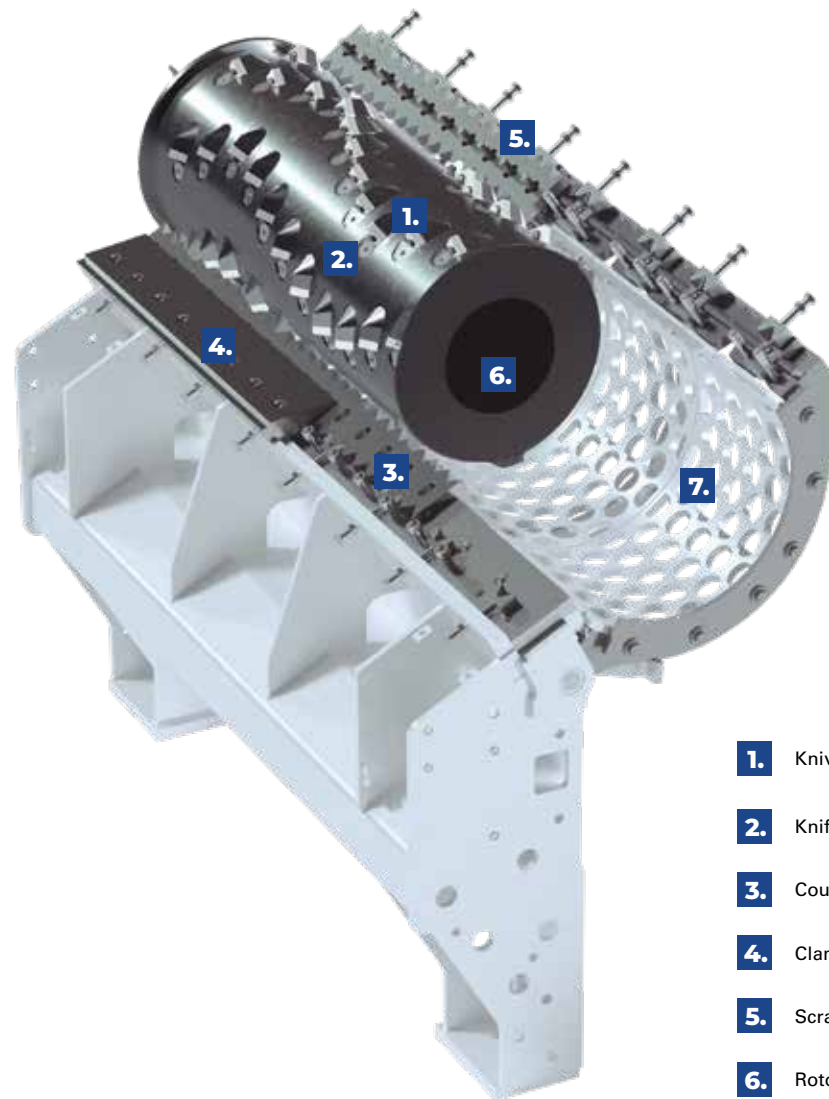

- 1. Knives
- 2. Knife holders
- 3. Counter knives
- 4. Clamping bar
- 5. Scraper
- 6. Rotor
- 7. Screen module

3 knife sizes, easy changeable



* Mono-Fix technology

- Water sprinkling system
- Fire prevention system
- Bale opener
- Rotor cooling
- High performance



Figure: gear drive

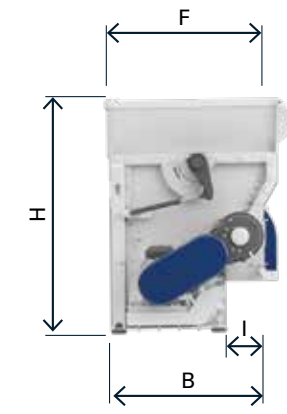

MICROMAT		1500	2000	2500	1500 HP	2000 HP	2500 HP
DIMENSIONS*							
Measure (LxBxH)	mm	3738 x 2478 x 3380	4217 x 2478 x 3380	4717 x 2478 x 3380	4519 x 2633 x 3380	5019 x 2633 x 3380	5519 x 2633 x 3380
Hopper opening (DxF)	mm	2290 x 2405	2790 x 2405	3290 x 2405	2290 x 2405	2790 x 2405	3290 x 2405
Filling height (G)	mm	2594	2594	2594	2594	2594	2594
Hopper volume	m ³	3,4	4,5	5,6	3,4	4,5	5,6
Outlet width (I)	mm	1725	2225	2725	1725	2225	2725
Total weight	kg	11700	13700	15700	12000	14000	16000
CUTTING UNIT*							
Rotor length	mm	1525	2025	2525	1525	2025	2525
Rotor speed**	min ⁻¹	63 – 134	63 – 134	63 – 134	265	265	265
Knives: 43P, 59S	pcs.	77	104	131	77	104	131
Knives: 65P	pcs.	50	68	86	50	68	86
Number of screens	pcs.	3	4	5	3	4	5
DRIVE UNIT*							
Motor	kW	1 x 90	1 x 132	1 x 160	1 x 110	1 x 132	1 x 160

* The stated values refer to standard machine versions with a standard hopper and raised feet. The right to make technical changes is reserved.
 ** Variable rotor speeds require optional electronic motor speed control system and gear configuration.

Typical input/output materials



ANTARES 1300 | 1600 | 1900

NEVER LOSES OUT.



Effective technology in compact design.

The Antares series will win you over with its robust design, convenient maintenance access and powerful performance – all the advantages of a Lindner shredder wrapped up in a compact machine. At the same time, the extensive range of sizes makes it possible to perfectly adapt the shredders to your downstream process. And all this with a smooth production flow and consistently defined particles.

- Robust and powerful asynchronous motor
- Cutting unit with pointed knives to ideally adapt to the material and particle size
- Easy machine access for quick and easy maintenance
- Mono-Fix technology for maximum flexibility and adaptation to input material and grain size

SINGLE-SHAFT UNIVERSAL SHREDDER WITH ROUBST AND PROVEN GEAR DRIVE

- 1. Skylight maintenance door
- 2. Sturdy gear drive
- 3. Optional safety clutch
- 4. Internal pusher
- 5. Cutting system
- 6. Plug & go screen unit

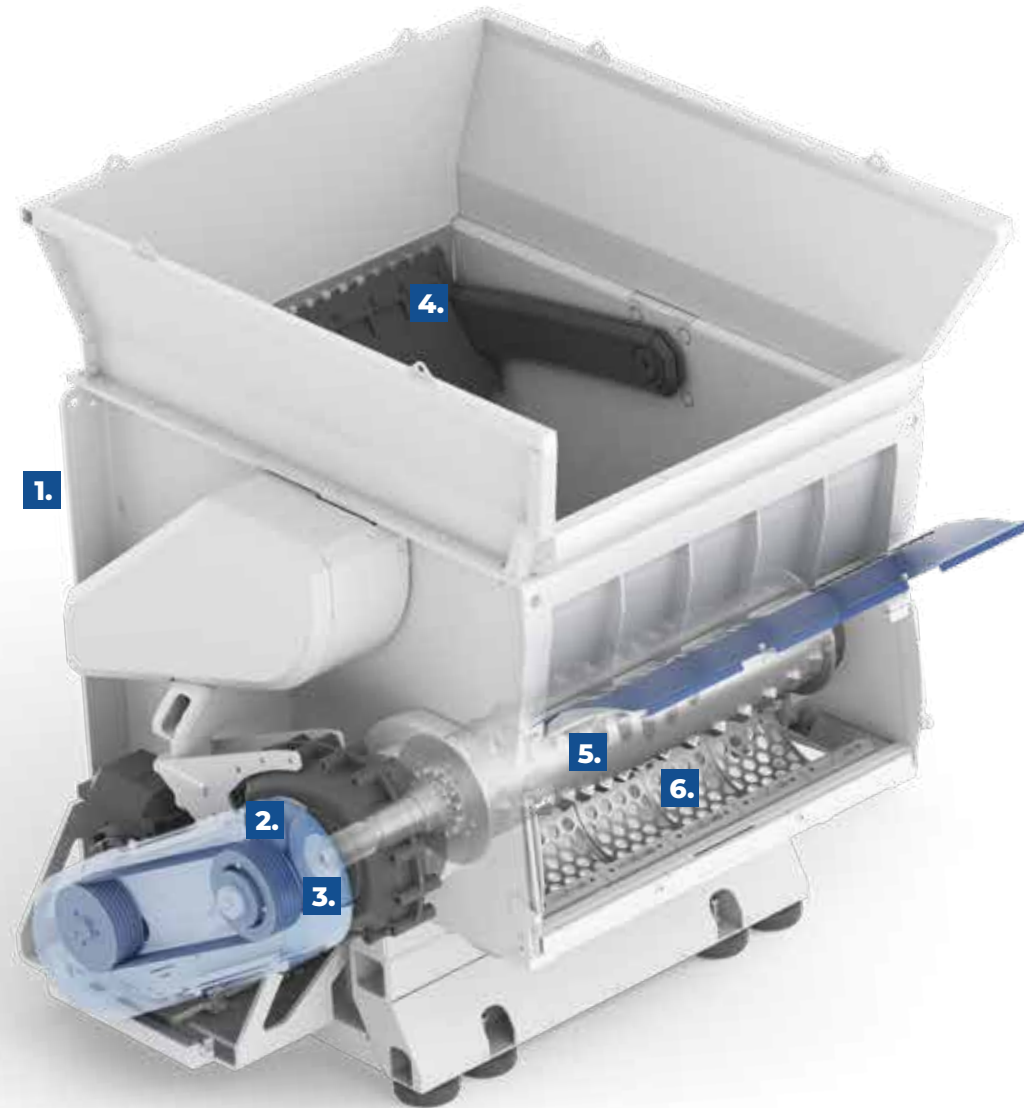

FLEXIBLE CUTTING SYSTEM

The Antares' individually configurable square cutting system ensures maximum output while taking up minimum floor space. The cutting system is designed with various applications in mind, ensuring efficient shredding of a wide range of materials.

- Optimum output thanks to knife configurations that can be individually adapted to the requirement
- Knives can be changed quickly and easily
- Constant grain is guaranteed by the variably adjustable cutting gap

ROBUST GEAR DRIVE

- Powerful shredding due to powerful motors with high torque
- Individual adaptation to the material through variable speeds
- Worldwide availability of the easy-to-change standard components

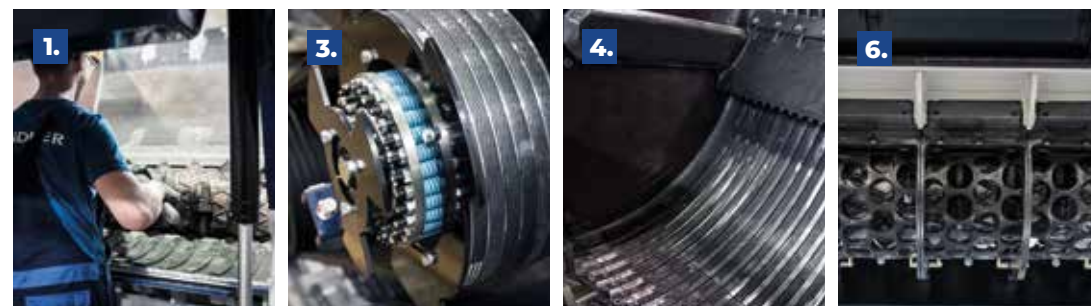

Detailed product information, pictures, videos here:



THE ANTARES SERIES CUTTING UNIT

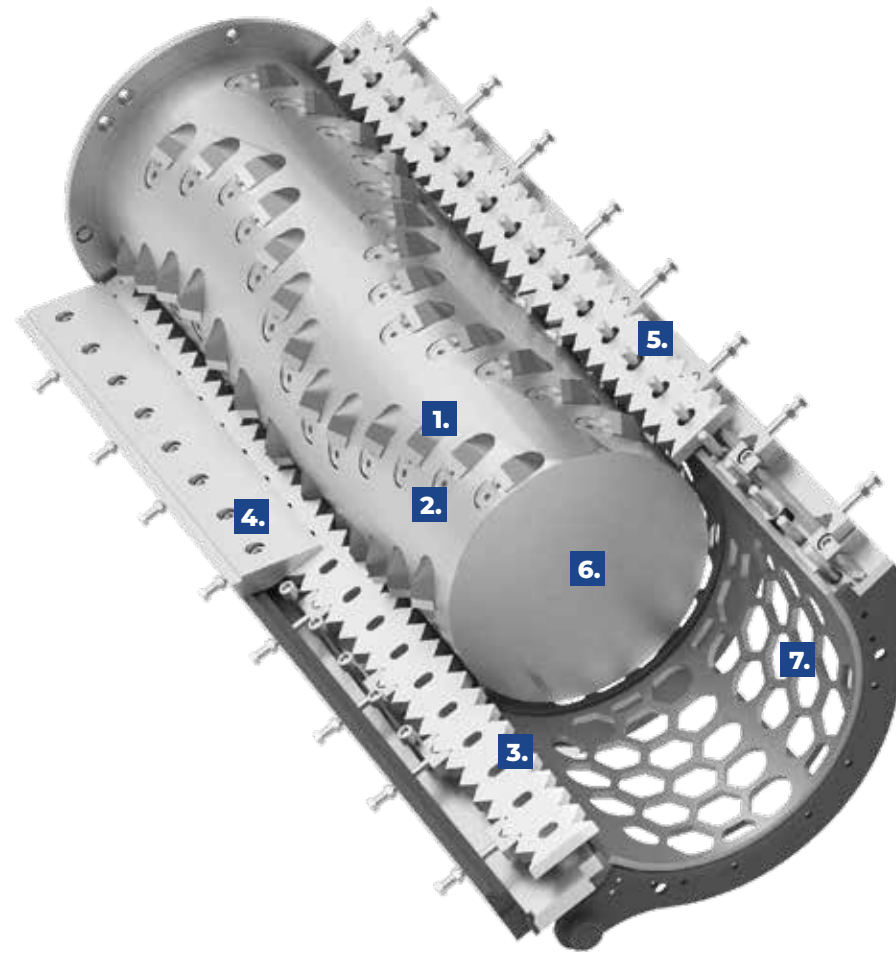

- 1. Knives
- 2. Knife holders
- 3. Counter knives
- 4. Clamping bar
- 5. Scraper
- 6. Rotor
- 7. Screen module

- Water sprinkling system
- FPS Fire prevention system
- Rotor cooling

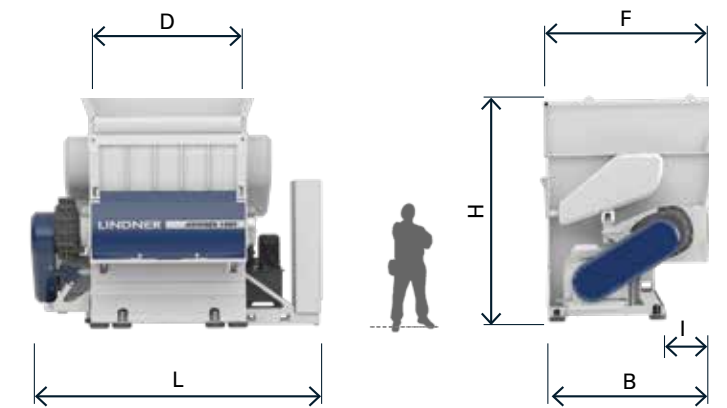

Typical input/output materials



ANTARES		1300	1600	1900
DIMENSIONS*				
Measure (LxBxH)	mm	3084 x 2628 x 2998	3393 x 2628 x 2998	3701 x 2628 x 2998
Hopper opening (DxF)	mm	1668 x 2486	1977 x 2486	3290 x 2486
Filling height (G)	mm	2425	2425	2425
Hopper volume	m ³	2,5	3,1	3,7
Outlet width (I)	mm	1305	1605	1915
Total weight	kg	7200	8000	8800
CUTTING UNIT*				
Rotor length	mm	1258	1567	1875
Rotor speed	min ⁻¹	62 – 130	62 – 130	100 – 130
Standard: pointed knives		43P 43PX 65P	43P 43PX 65P	43P 43PX 65P
Number of knives	Stk.	48 56 32 32	60 70 40 40	72 84 48 48
Number of screens	Stk.	4	5	6
DRIVE UNIT*				
Gear drive		✓	✓	✓
Motor	kW	1 x 75	1 x 90	1 x 90

* The stated values refer to standard machine versions with a standard hopper and raised feet. The right to make technical changes is reserved.

SERVICE FOCUS.



Lindner's service – simply offering more.

Commitment and professionalism coupled with extensive expertise and original Lindner spare parts made in Austria ensure top quality service and highest machine availability. Individual service solutions mean maximum flexibility and the least downtimes – any day, every day.

Service à la Lindner:

- Available 24/7 – worldwide
- Remote assistance – fast help with remote maintenance
- High availability of spare parts thanks to extensive in-house production
- Original Lindner spare parts made in Austria for that extra level of quality

Maintenance – to keep everything running smoothly:

- Flexible maintenance offers for high machine availability
- Spare part packages for every application
- Qualified shaft reconditioning & hardfacing in line with the highest international standards

Lindner-Recyclingtech GmbH

Manuel-Lindner-Strasse 1 | 9800 Spittal/Drau | Austria
t.: +43 4762 2742 | f.: +43 4762 2742-9032 | office@lindner.com

www.lindner.com